



**P-ISSN: 2349-8528**

**E-ISSN: 2321-4902**

[www.chemijournal.com](http://www.chemijournal.com)

IJCS 2020; SP-8(5): 45-48

© 2020 IJCS

Received: 28-07-2020

Accepted: 30-08-2020

**Dr. P Rajaiah**

AICRP on FIM Scheme,  
PJ TSAU, Telangana,  
Hyderabad, India

**B Laxman**

AICRP on FIM Scheme,  
PJ TSAU, Telangana,  
Hyderabad, India

**Dr. B Vennela**

AICRP on FIM Scheme,  
PJ TSAU, Telangana,  
Hyderabad, India

**A Pramod Reddy**

AICRP on FIM Scheme,  
PJ TSAU, Telangana,  
Hyderabad, India

**Corresponding Author:**

**Dr. P Rajaiah**

AICRP on FIM Scheme,  
PJ TSAU, Telangana,  
Hyderabad, India

## Development and evaluation of mini tractor operated ridge plastering machine

**Dr. P Rajaiah, B Laxman, Dr. B Vennela and A Pramod Reddy**

**DOI:** <https://doi.org/10.22271/chemi.2020.v8.i5a.10369>

**Abstract**

Mechanization of bund or ridge forming is an important process in the preparation of the rice field before transplanting. Presently, the untilled soil near the bunds and corners of the field are prepared manually which is consuming more time and energy. The traditional manual bund/ ridge forming work is characterized by low efficiency, low strength, high cost and directly affects the profitability of rice farming. More over manually made bunds not properly aligned and compacted not last for long and causing rodent problem. Tractor drawn (35-45 hp) ridge plastering machines are commercially available to make or plaster the existing bunds by utilizing the tractor full P.T.O power which is not required for the purpose of making mere bunds . The same bunds also can be done by 18-25 hp range small tractors. Now a days mini tractors also being manufactured in India to address the mechanization problems of small and marginal farmers. In this context, a mini tractor operated ridge plastering machine was developed at FIM, Scheme, Rajendranagar, Hyderabad, Telangana and evaluated in sandy loam soil with a moisture content of 31%. The machine can be operated with 18-25 hp range mini tractors. This attachment weighs about 390 kg with overall dimensions of 1,620mm length, 1,660mm width and 1,130mm height. The blades on the periphery of the disc pulverises the soil, the leveller levels the soil, and the rotating disc trims the bund and plasters it with pulverised soil. The roller attached to the rotating disc compresses the soil. During the field study, it was observed that, the field capacity of the machine was 833 m per hour with an average speed of 1.0 km/h. Overall dimensions of bund was 178 mm height and 288 mm width respectively. The angle between ground and the side wall of the bund is 120°. The fuel consumption of the machine was 3.42 l/h. The cost of operation of the machine was Rs. 700-800/ h. The cost saving was Rs.2000-2500/h over conventional method. This machine is suitable for both dry and wet conditions.

**Keywords:** Mini tractor, ridge plastering machine, cost of operation and rotating disc

**Introduction**

The use of conservation and minimum tillage methods improves soil health, reduces soil erosion and reduces costs. The appropriate and sustainable agricultural mechanization plays a major role in making agriculture sustainable. To overcome this problem and to achieve sustainability in agriculture, mechanization of agricultural activities plays a major role which could eventually give a better solution to the labour shortage in agriculture. Farm mechanization should be in such a way so as to develop appropriate technologies to suit local condition which are compatible with the socioeconomic and field conditions. Field making, transplanting, weeding and harvesting operation have already been completely mechanised. Ridge plastering, an operation where field bunds are trimmed and thereafter plastered and compacted using the earth excavated, was being done manually.

In traditional method, bunds are usually done in two steps at the beginning of the each crop season. First, the bund should be cleared from weeds and grass before initial ploughing. Then the bund should be plastered with a layer of mud after the second plough. Good bunds help to limit water losses by seepage and under bund flows. Bunds should be well compacted and any rat holes should be plastered with mud. Manually, an average skilled person can trim and plaster 90-120 m of bund per day. Therefore, an attempt was made to mechanize this bund making process to strengthen the existing bund (ridge) without damaging the height of the ridge. This machine is suitable for both dry and wet conditions. A local made machines can bring down the cost. Hence, a simple, effective and indigenous mini tractor operated ridge plastering machine was developed for small and marginal farmers.

**Materials and Methods**

The design and development of Mini tractor operated ridge plastering machine was carried out at FIM Scheme, Rajendranagar, Hyderabad. The Mini tractor was identified as power source for the fabrication of ridge plastering machine. The Mini tractor is of 18 Hp water cooled diesel engine with forward gear and reverse gears. The overall weight of the machine is 143 kg along with rotavator.

The power is taken from the PTO of mini tractor for fabrication of ridge plastering machine by replacing rotavator. Hydraulic power of tractor is used to change the direction of operation as well as the precise adjustment for ridge plastering. The PTO drive is connected to the transmission unit of the machine, from where power is distributed to the rotating parts. The Ridge plastering mechanism consists of a frame, rotary mechanism with blades, plastering disc, chain, and sprockets and plastering cylinder. A rectangular frame of 610 x 240 mm was fabricated using hallow 50 mm square pipe with 6 mm thickness for mounting of ridge plastering mechanism. To develop ridge plastering mechanism a shaft

with 60 mm outer diameter and 38 mm inner diameter was fabricated to transfer the power from PTO to the rotary mechanism with the help of a flange. Blades with 6 mm thickness of 10 numbers were fitted one side on the periphery of the shaft for cutting grass and pulverizing the soil.

The plastering mechanism was fabricated with 500 mm diameter disc, 12 number of trapezoidal blades are fitted on the periphery of the disc and 155 mm cylinder is fixed to the outside of the disc with help of shaft and flange for plastering the pulverized soil with rotary mechanism for compression. A 250 mm diameter sprocket with 30 teeth is arranged to transfer the power from rotary mechanism to the plastering mechanism with help of chain and sprocket mechanism. The plastering mechanism is fitted on the rear side of the rotary mechanism with the help of 35 mm diameter shaft at one side, on the other end of the shaft, 15 mm diameter sprocket with 15 teeth was arranged for taking the power from rotary mechanism. The specifications of the prototype ridge plastering machine are presented in (Table1).

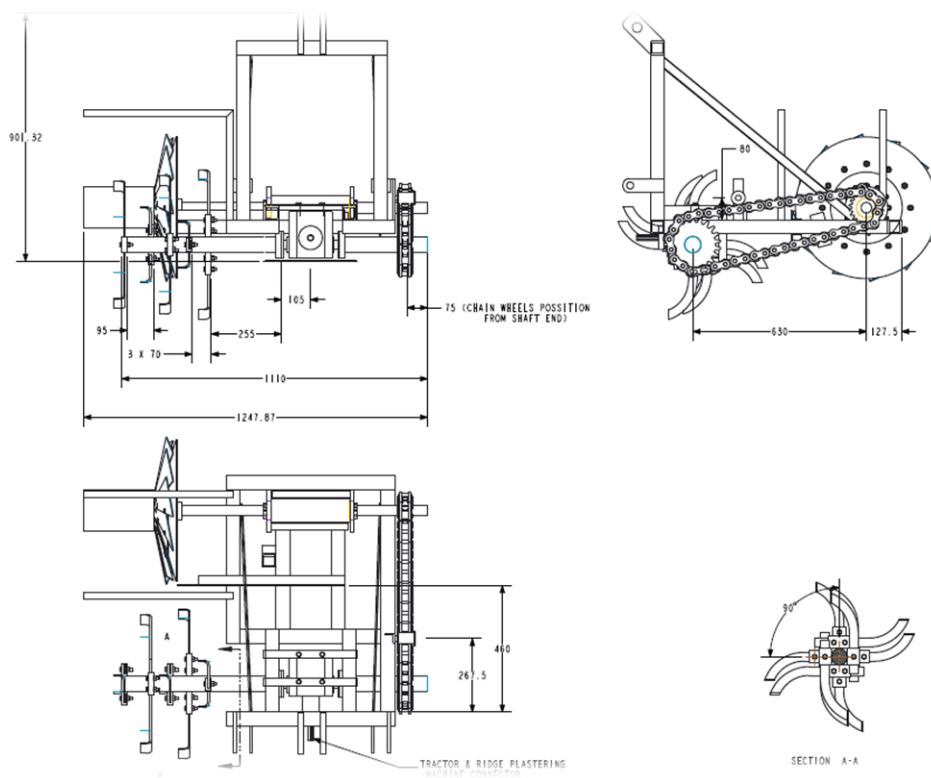

**Fig 1:** 2-D views of mini tractor operated ridge plastering mechanism

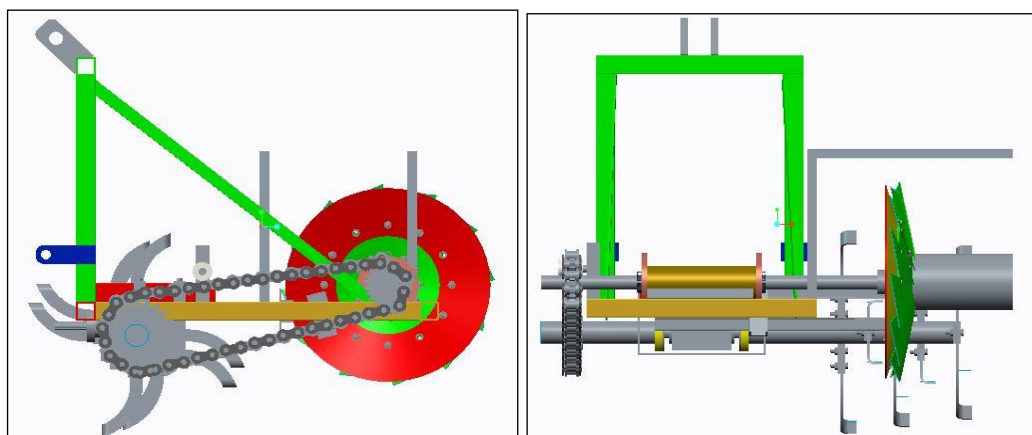

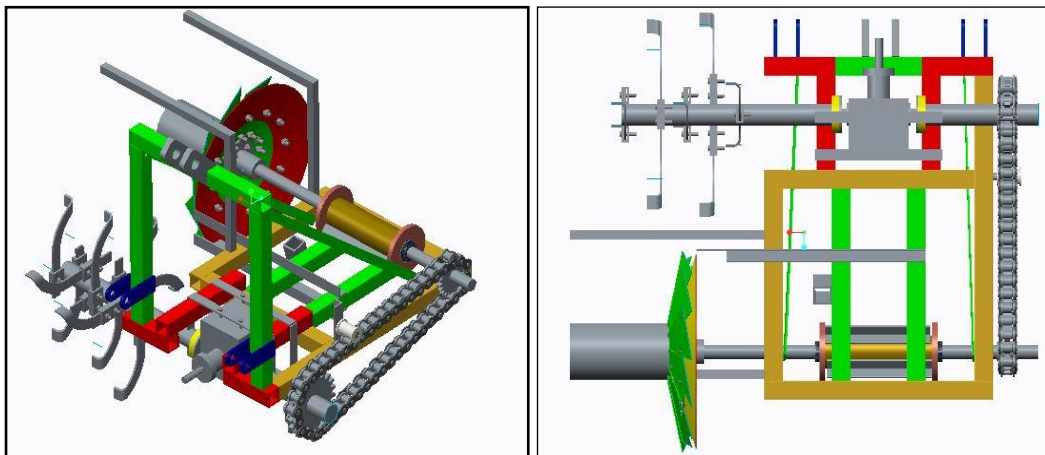

**Fig 2:** Different conceptual views of mini tractor operated ridge plastering machine



**Fig 3:** Mini tractor operated prototype ridge plastering machine

**Table 1:** Specifications of mini tractor operated prototype ridge plastering machine

S. No.	Component	Details
1	Mini Tractor Make and Model	VST Mitsubishi Shakti MT 180D
2	Type	3 cylinder 4-stroke water cooled diesel engine
3	Horse power	18
4	Weight of Mini Tractor along with ridge plastering machine, kg	829
5	Overall Dimensions of the mini tractor including ridge plastering machine, mm	3640×1247×1350
6	Overall Dimensions of ridge plastering machine, mm	1127×1247×901
7	Weight of ridge plastering machine, kg	143
8	Number of blades	10
9	Length of each blade, mm	260,230,210 & 180
10	Diameter of the ridge plastering Disc, mm	500
11	No. of blades on the periphery of the disc	12
12	Diameter of compacting roller, mm	150

### Results and Discussion

Field trials were conducted at AICRP on Farm Implements and Machinery Scheme, Rajendranagar in a plot size of 20 × 20 m<sup>2</sup> in loamy soil (Fig 4.). The developed prototype ridge

plastering machine was operated at a forward speed between 2 – 2.7 kmph. The width and height of the bund was measured and presented (Table.2).



**Fig 4:** Field operation of mini tractor operated prototype ridge plastering machine

**Table 2:** Field performance of mini tractor operated ridge plastering machine

S. No	Parameter	Value			Average
		I	II	III	
1	Forward Speed, Kmph	2.3	2.4	2.13	2.27
2	Speed of rotary blades, rpm	230	220	235	228
3	Speed of ridge plastering disc, rpm	320	336	327	327
4	Width of the bund, mm	290	285	290	288
5	Height of the bund, mm	175	180	180	178
7	Fuel consumption, l/h	3.25	3.56	3.46	3.42
8	Moisture content, %	31	32	30	31
9	Field capacity, m/h	825	840	835	833
10	Labor required	1	1	1	1

During the field trails the ridge plastering machine has made a bund with 288 mm height and 178 mm width. The capacity of the machine was found to be 833 m/h with a cost of operation of Rs. 700 – 800/-.

### Conclusions

The developed prototype ridge plastering machine is viable technology to reduce cost of operation compared to manual trimming/formation of bunds and also reduces the human drudgery, the ridge plastering machine has an output of 833 m/h. The developed prototype machine is most useful for small scale farmers as the cost of the machine is Rs.60, 000/-. It saves the cost of operation about Rs.2000-2500/- over traditional methods.

### References

- Huang HC, Liu CW, Chen SK, Chen JS. Analysis of percolation and seepage through paddy bunds. *Journal of Hydrology*. 2003, 13-25.
- Rahul A, Prasanth G, Rajaiah P. Performance Evaluation of Tractor Operated Ridge Plastering Machine. *International Journal of Current Microbiology and Applied Sciences*. 2018; 7(7):631-636.
- Singh SP, Solanki RC, Singh MK, Singh K. Development of tractor operated bund former- cum- packer for increasing resource productivity. *Indian Journal of Agricultural Sciences*. 2016; 86(9):21-26.
- Singh SP. Development and Performance Evaluation of Powered Harrow Plough. M Tech.thesis, Department of Farm Machinery and Power Engineering, G B Pant University of Agriculture and Technology, Pantnagar, 1991.
- Singh Surendra. Farm machinery – Principles and Applications. Directorate of Information and Publications on Agriculture, Indian Council of Agricultural Research, New Delhi, 2007.